

Metro 800 io

Metro 1000 io

- PL** INSTRUKCJA MONTAŻU - ILUSTRACJE
- EN** INSTALLATION MANUAL - ILLUSTRATIONS
- DE** IINSTALLATIONSANLEITUNG - ABBILDUNGEN
- FR** MANUEL D'INSTALLATION - ILLUSTRATIONS
- IT** MANUALE D'INSTALLAZIONE - ILLUSTRAZIONI
- NL** INSTALLATIEGIDS - ILLUSTRATIES

Ref. 5132697A



WIŚNIEWSKI powered by **somfy**®

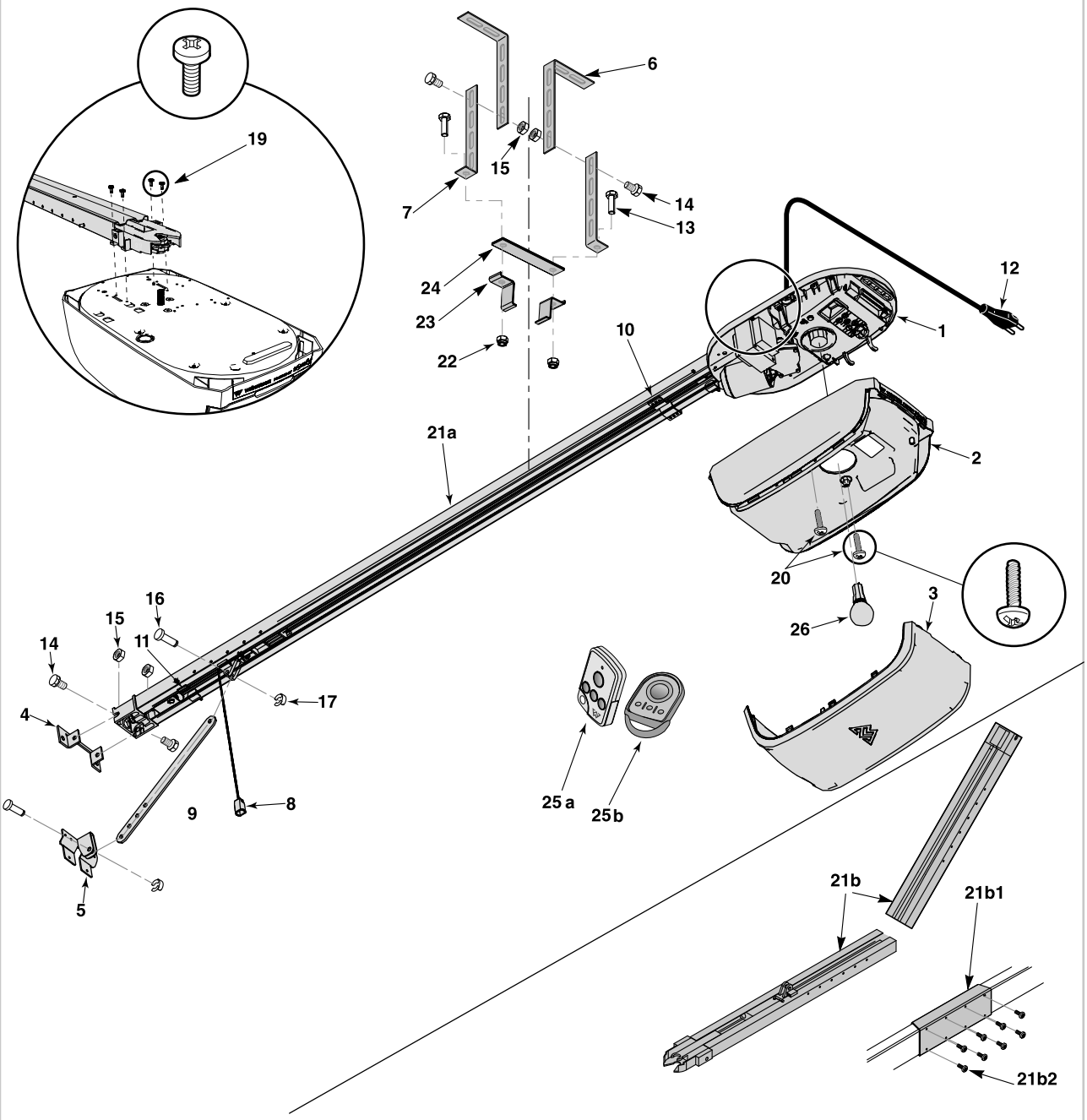
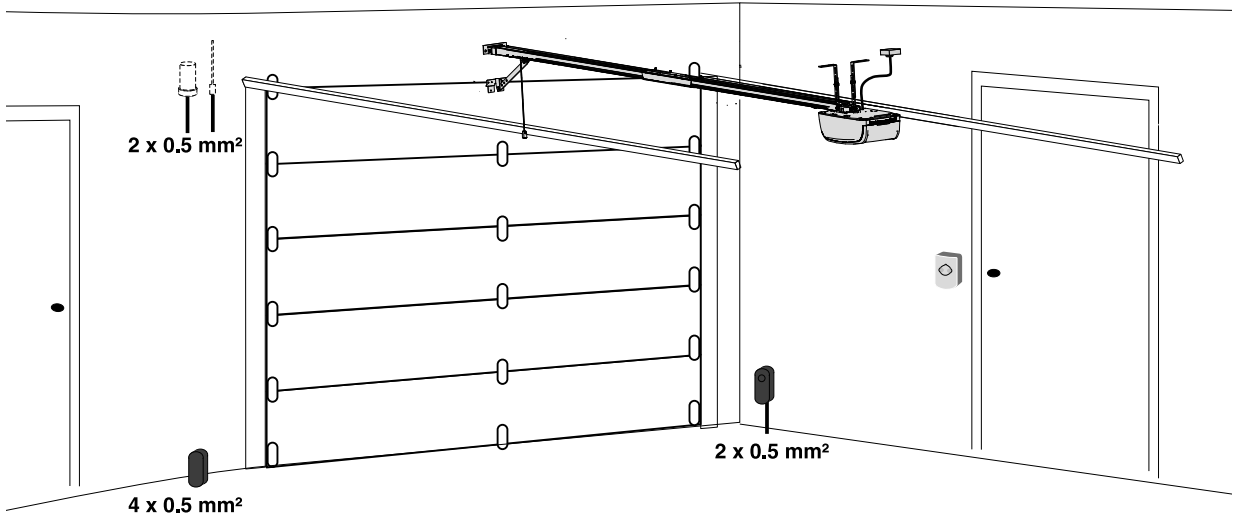

2

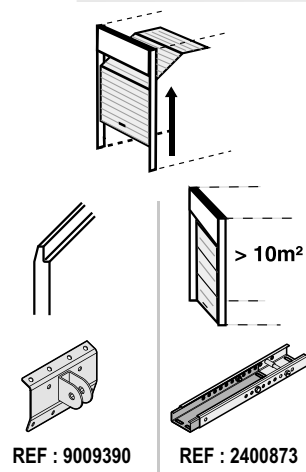

3

Metro 800 io

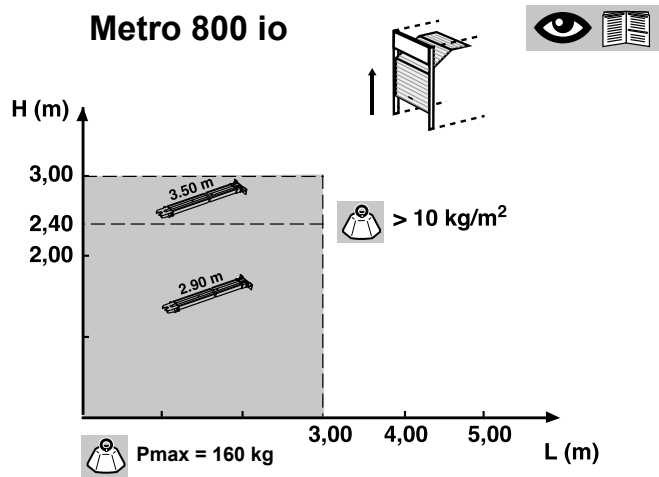

Metro 1000 io

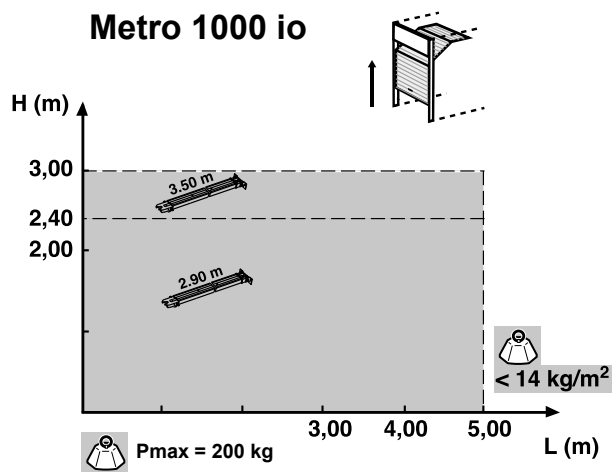

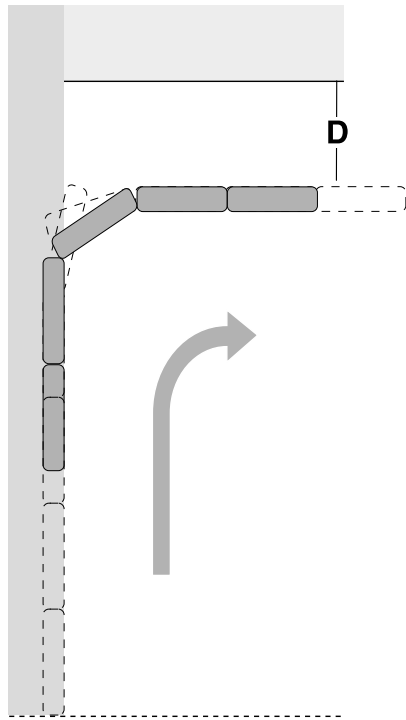
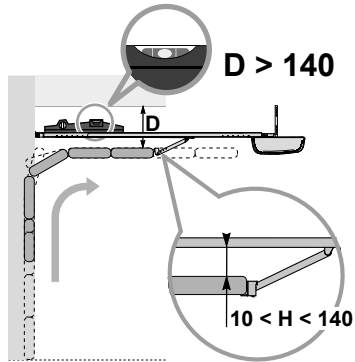
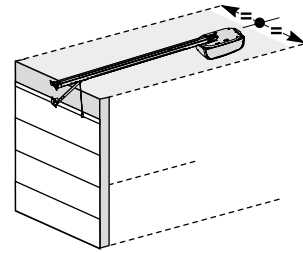
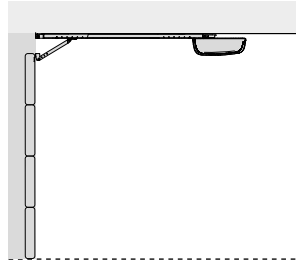
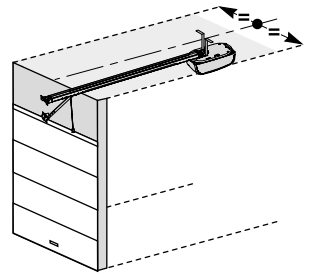
 $35 < D < 140$  $D > 140$ $10 < H < 140$ 

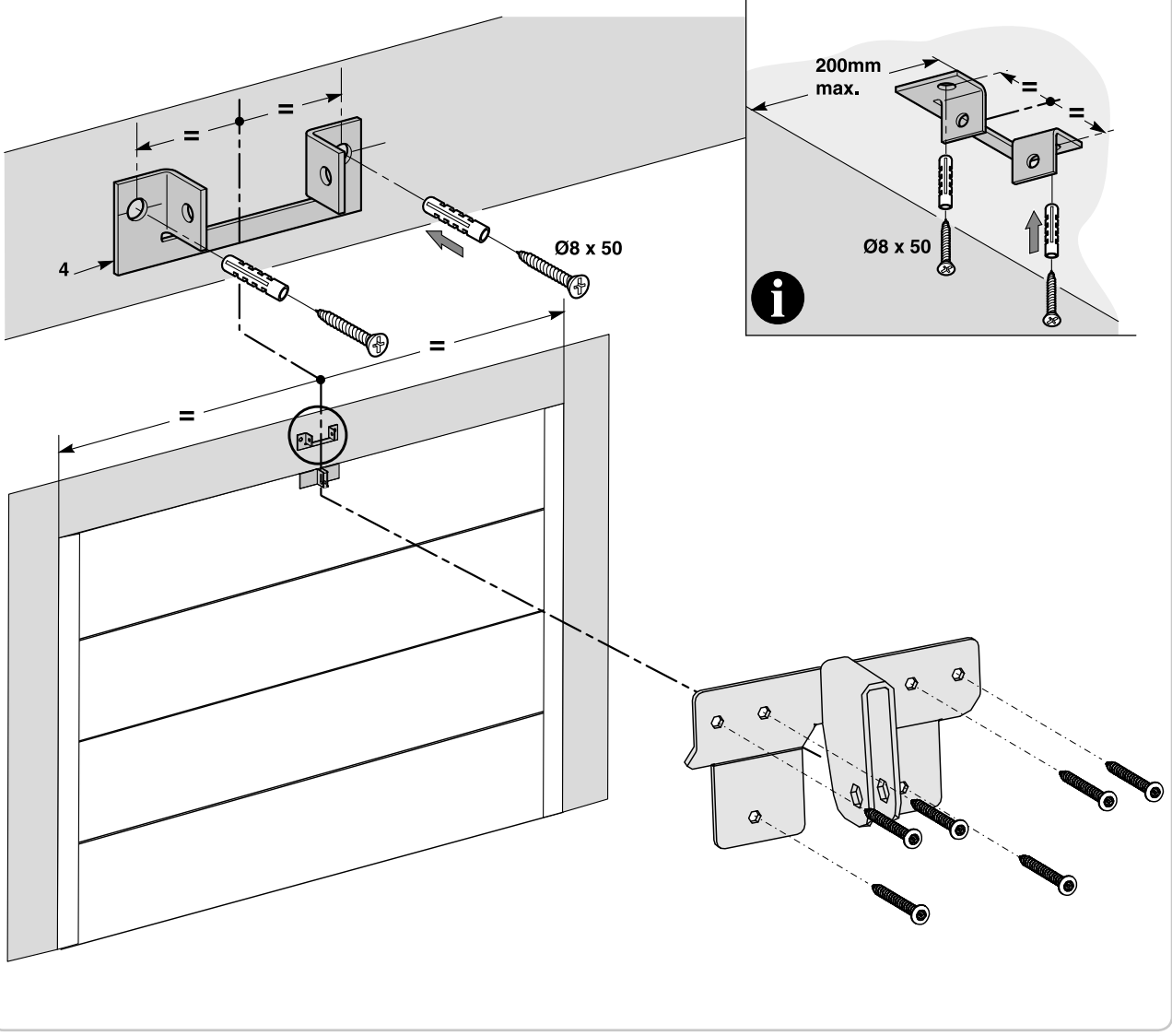

6

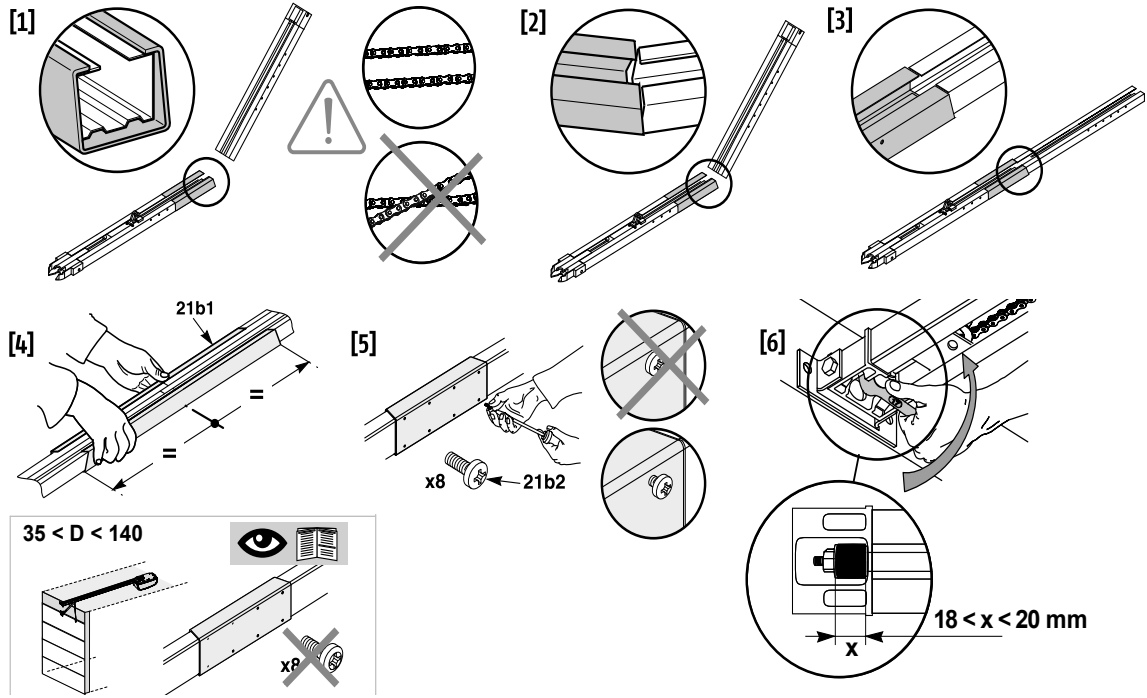

7

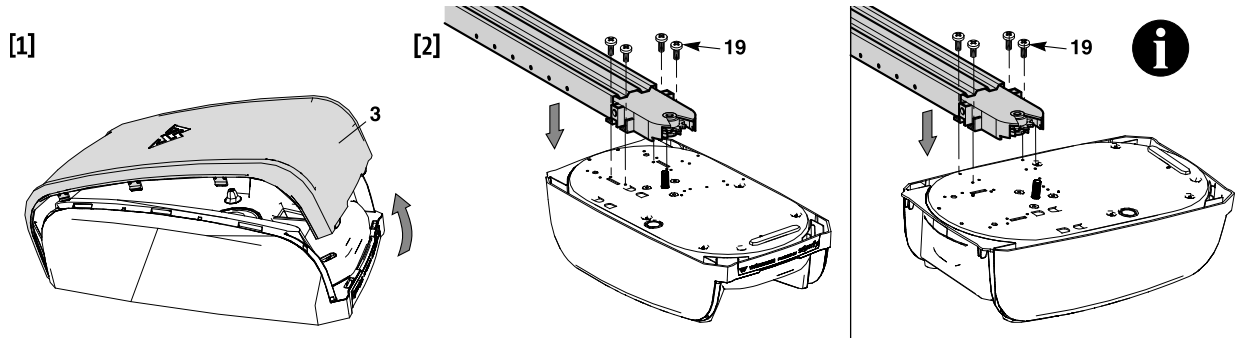

8

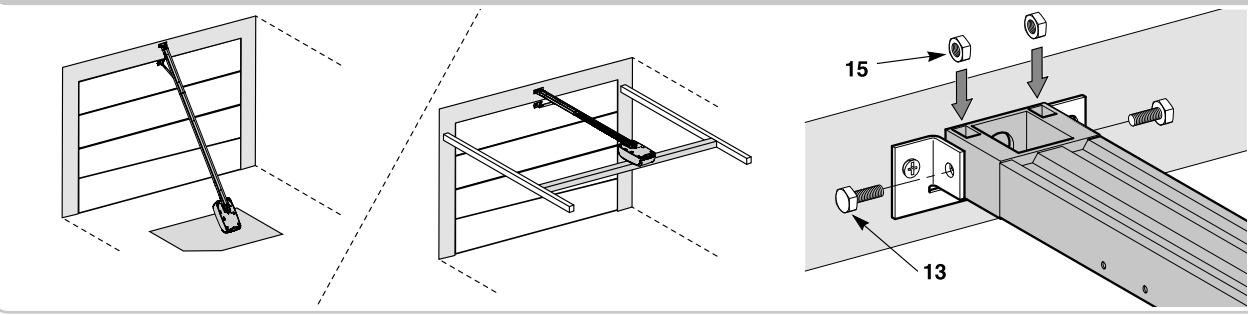

9

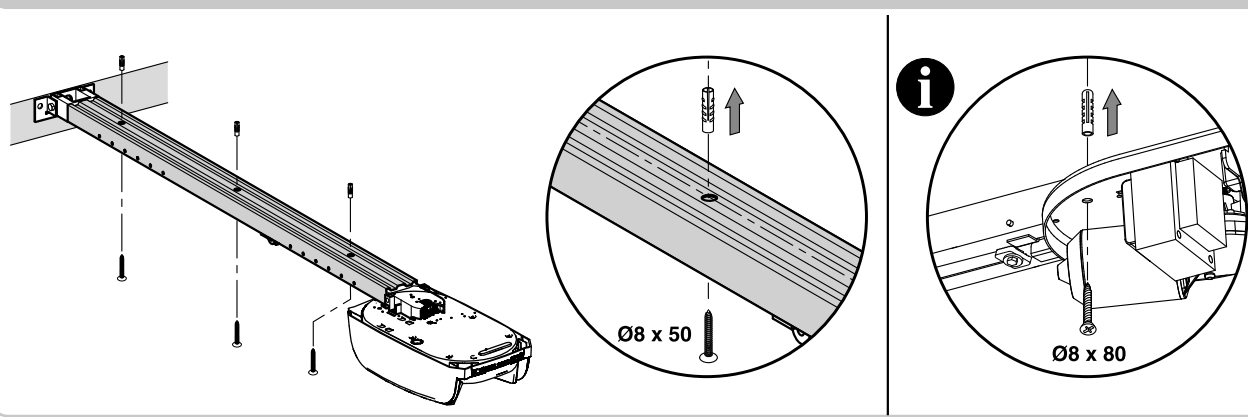

a

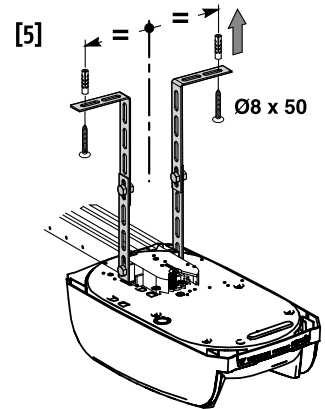
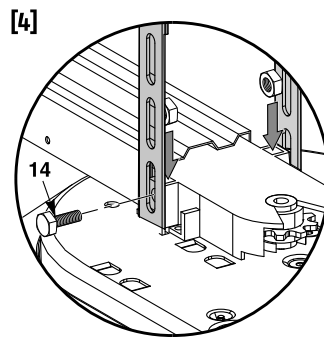
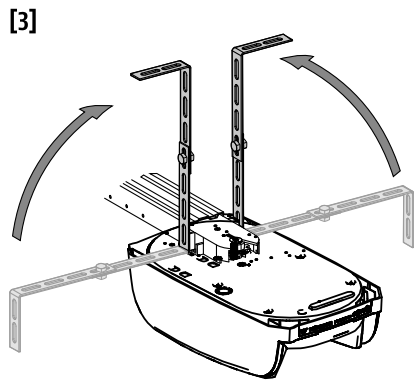
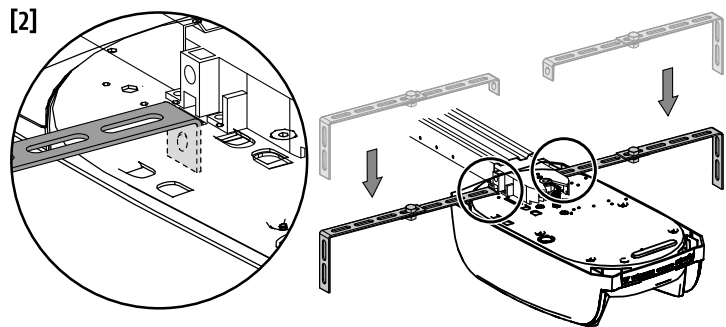
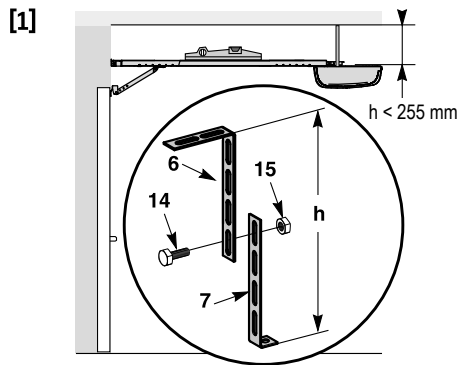

b

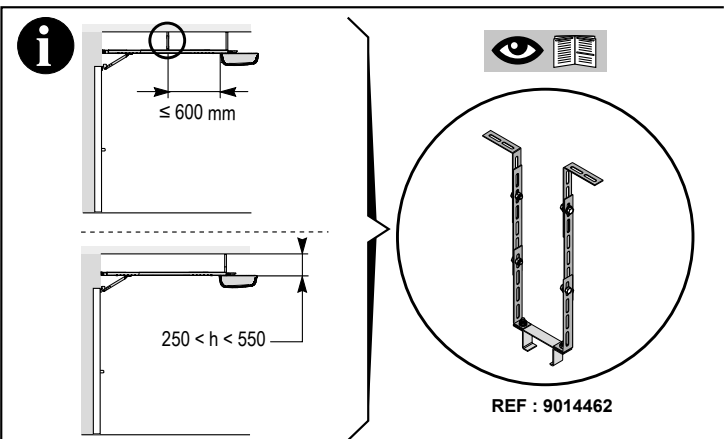
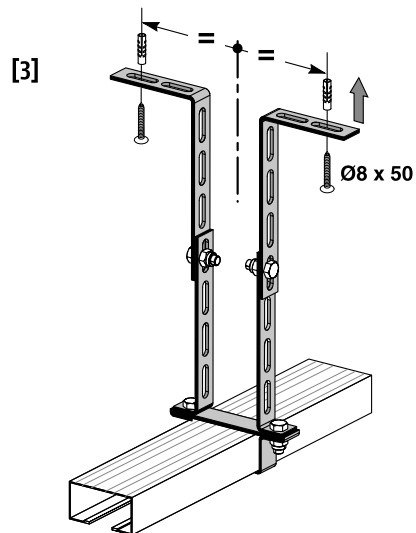
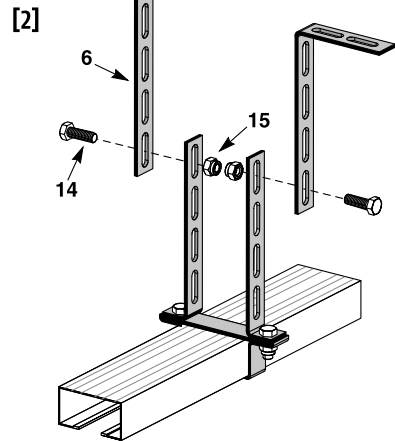
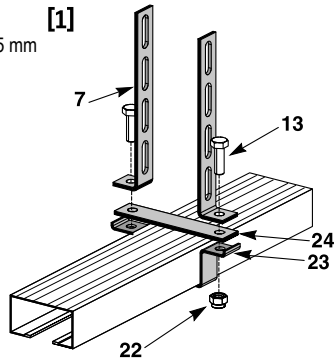
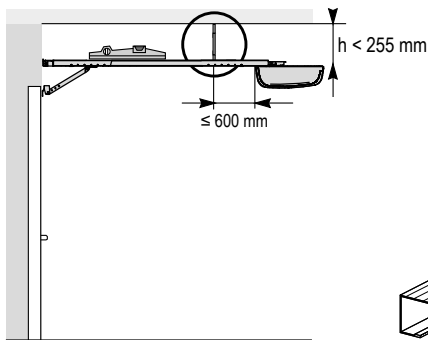

11

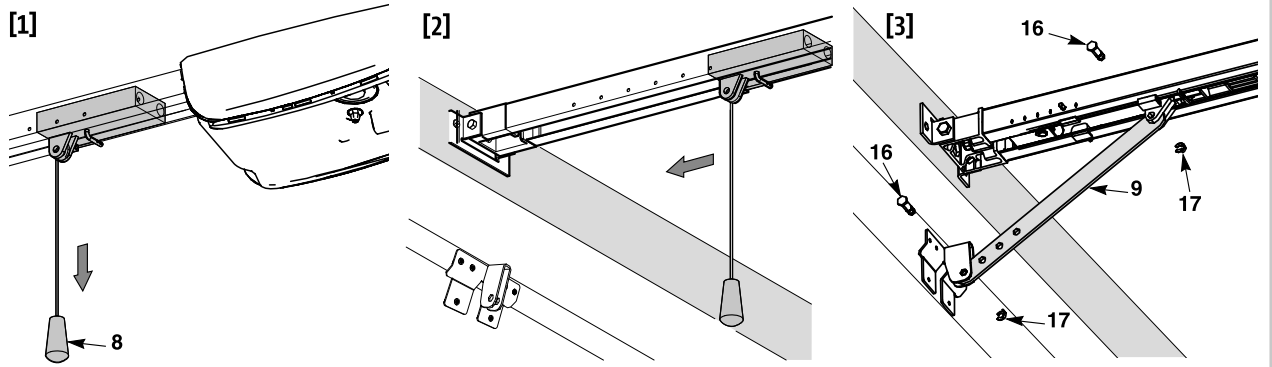

12

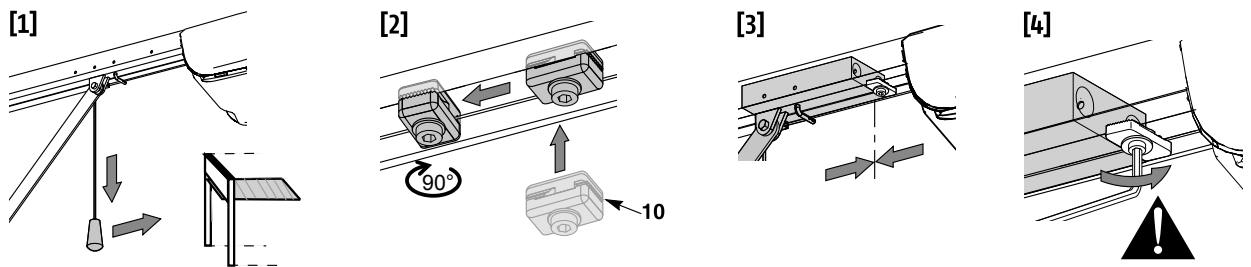

13

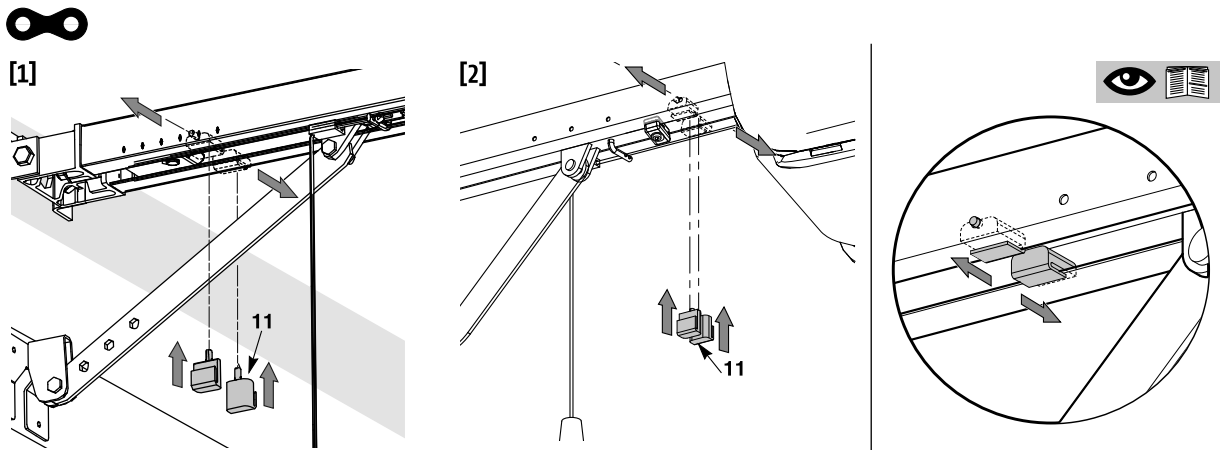

14

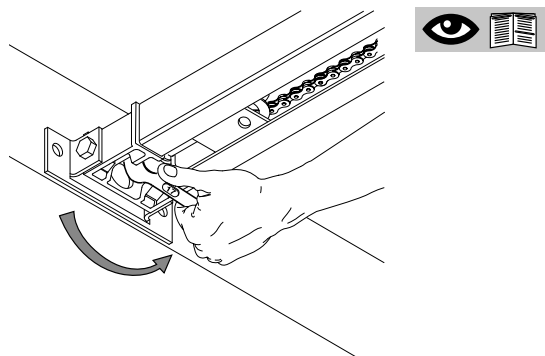

15

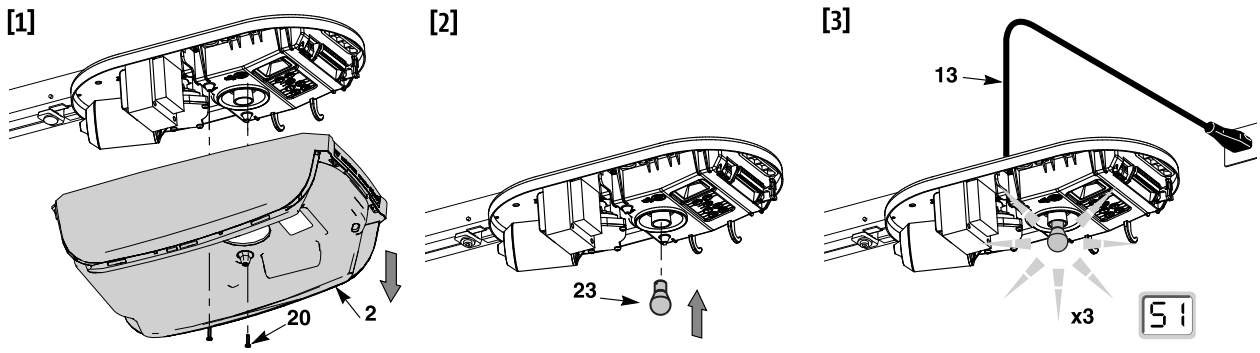

16

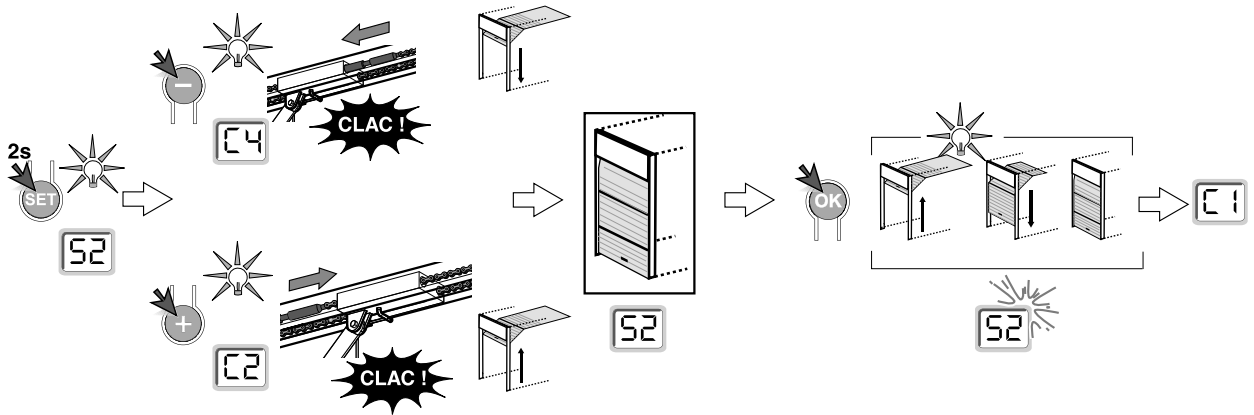

17

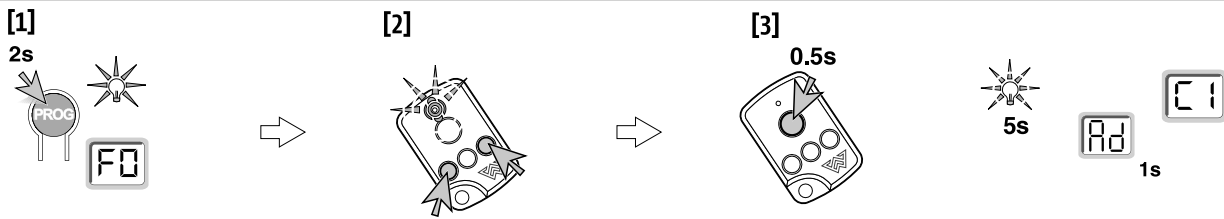

18

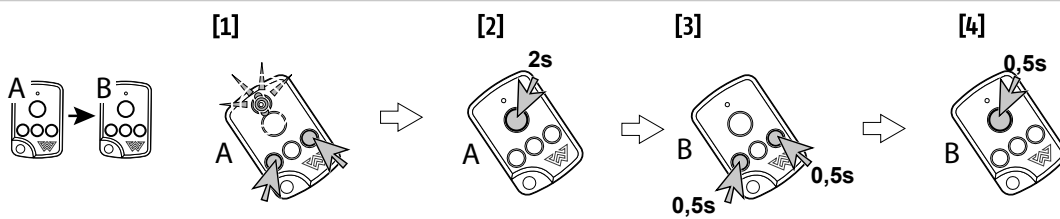

19

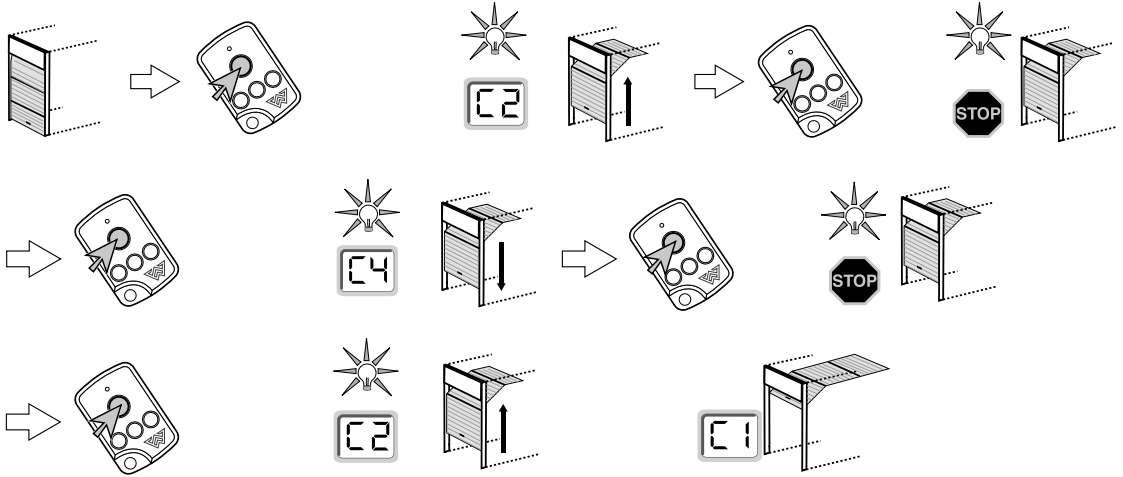

20

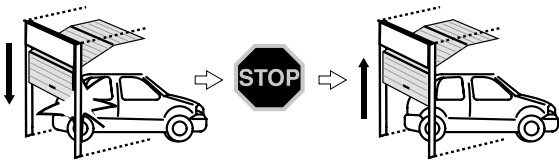

21

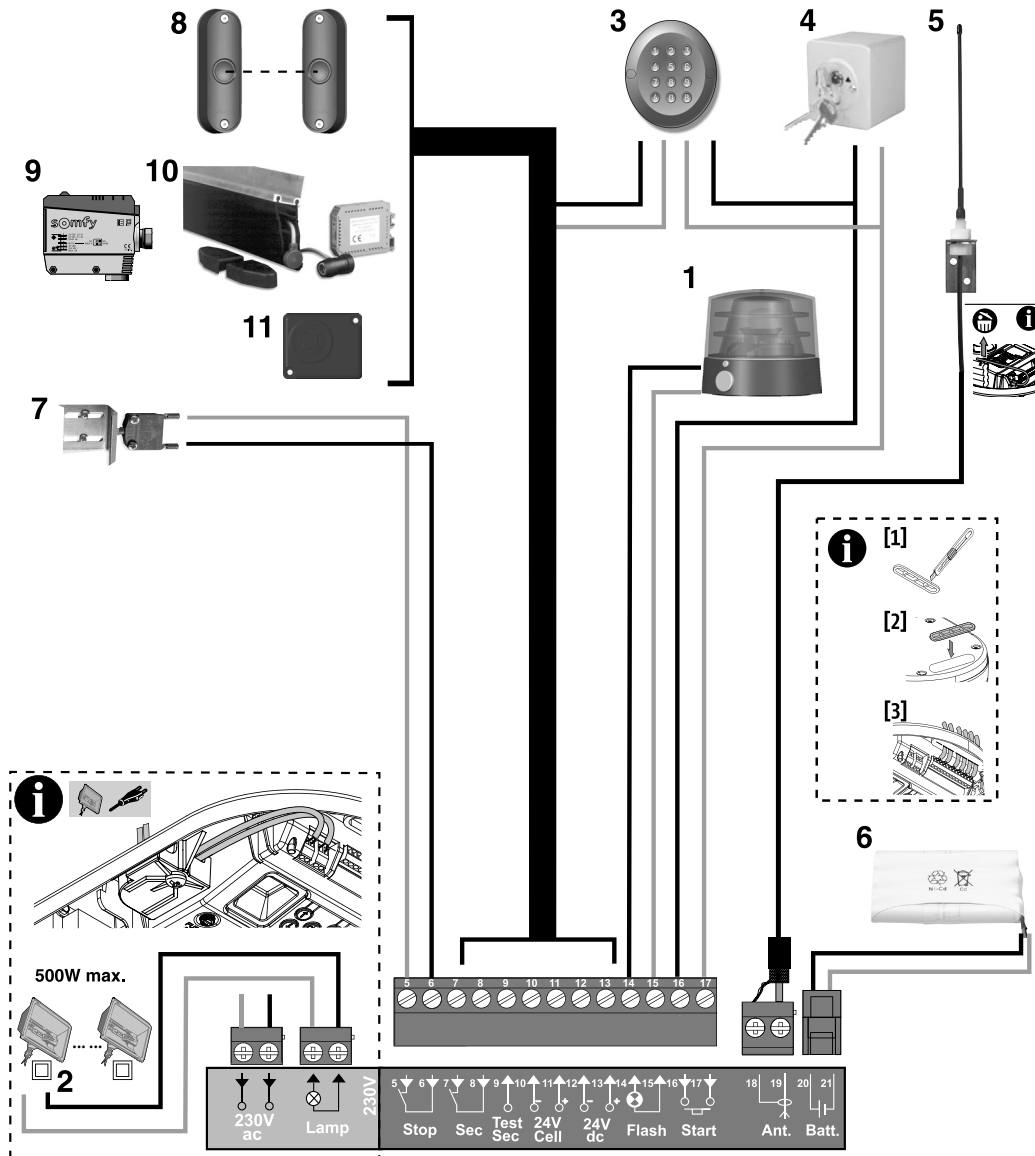

22

A P2 = 2

P2 R0 R1

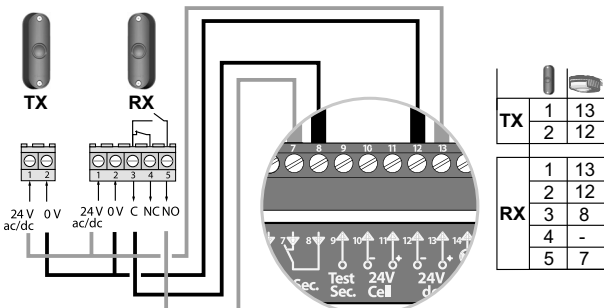

B P2 = 1

P2 R0 R1

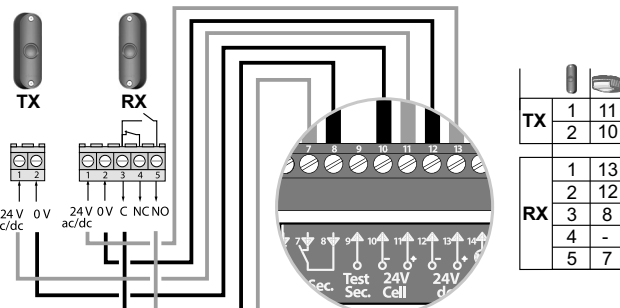

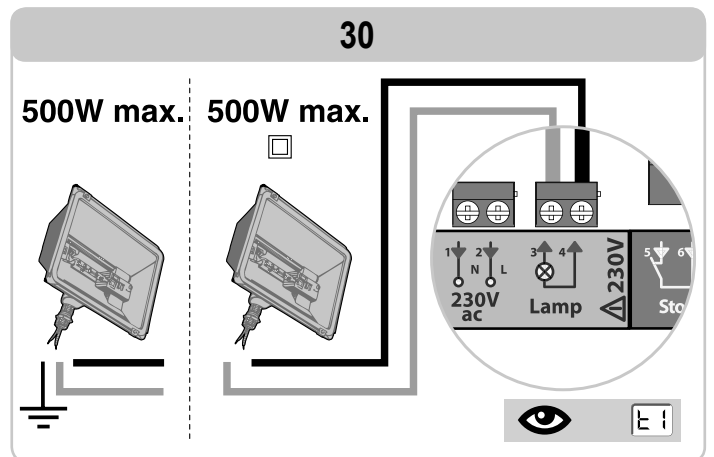
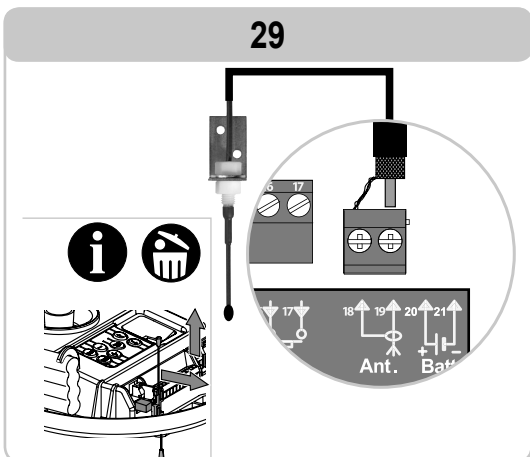
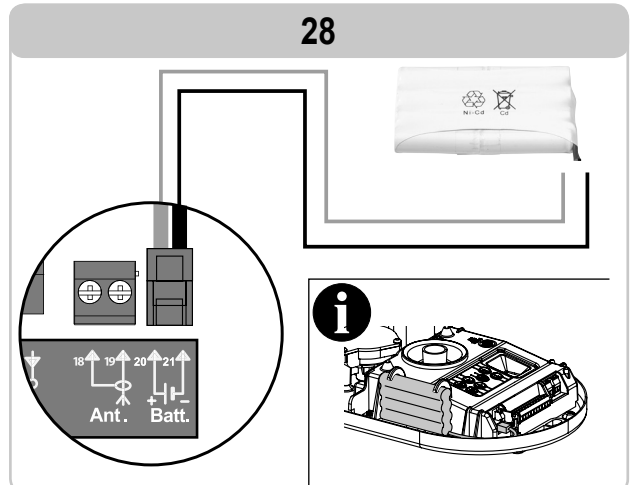
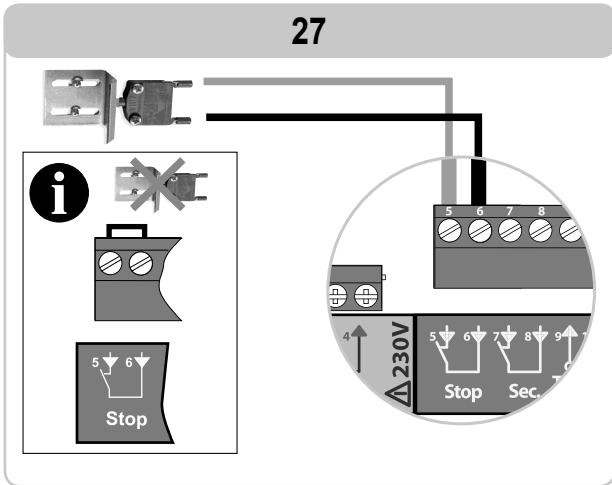
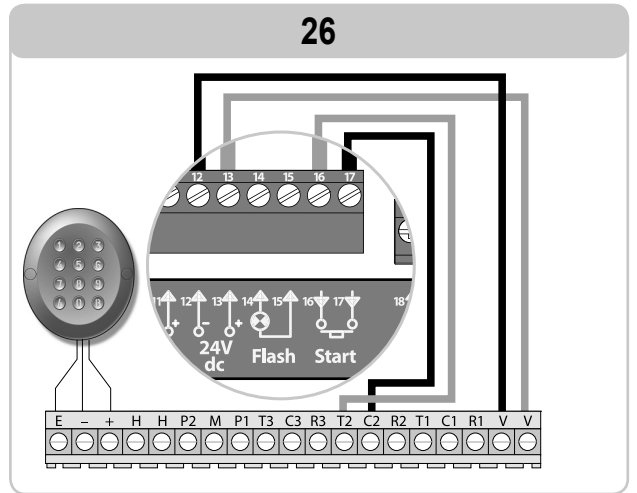
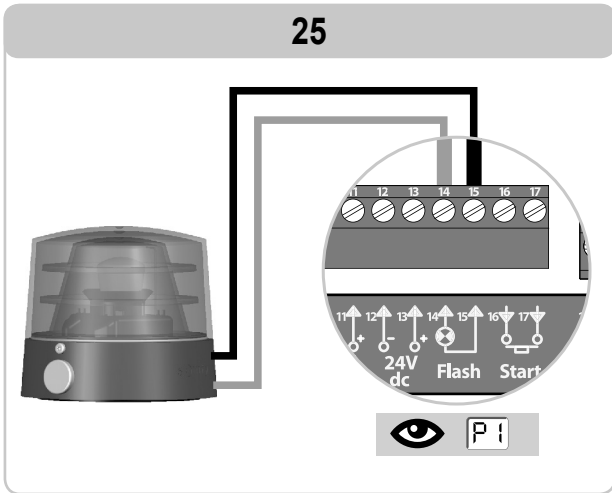
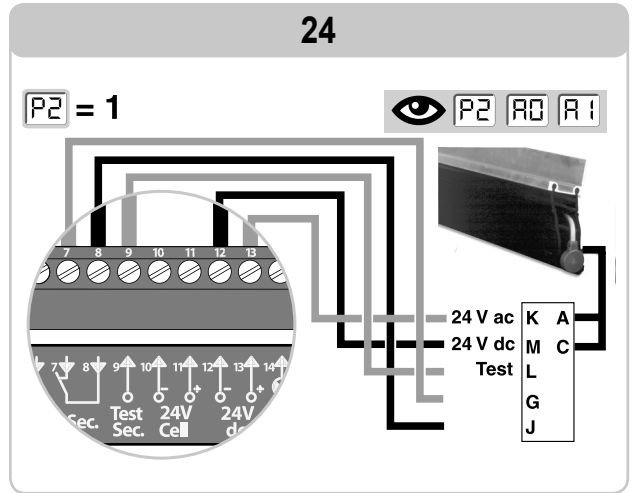
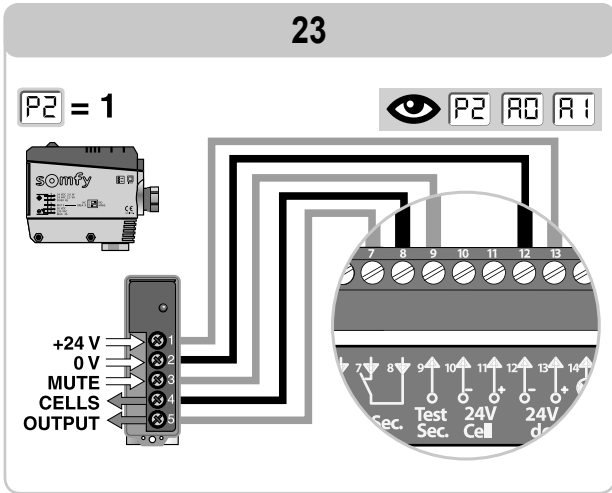

31

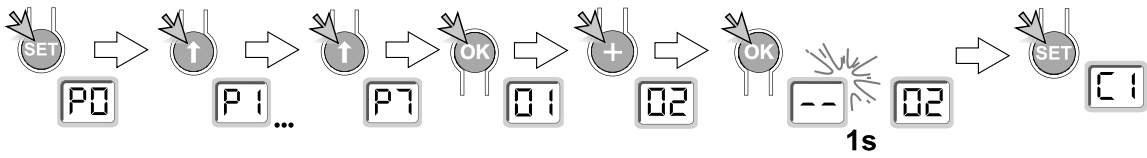

32

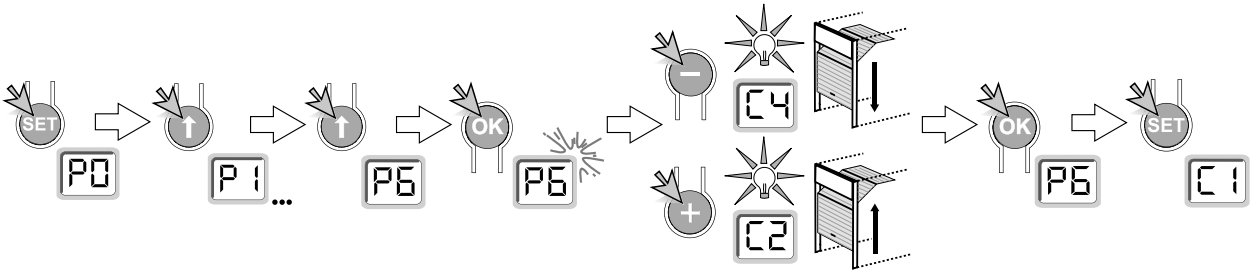

33

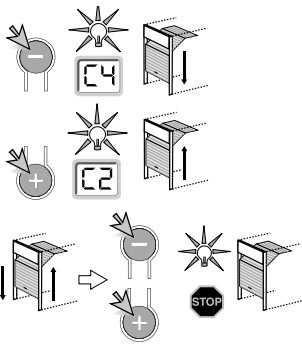

34

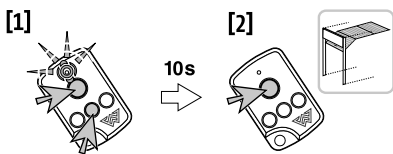

35

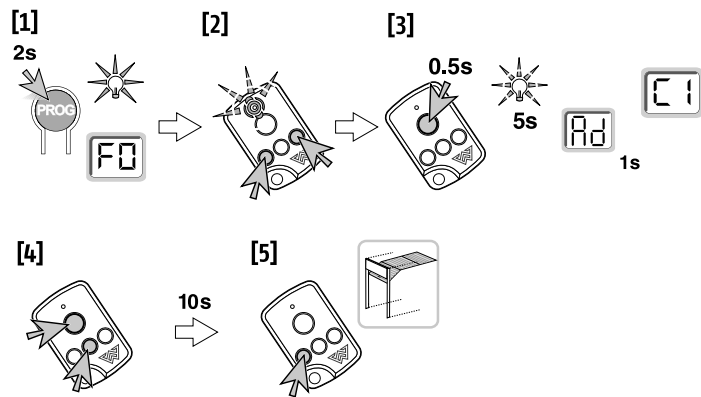

36

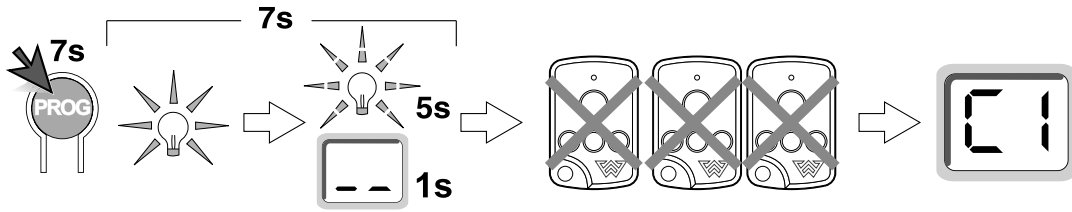

37

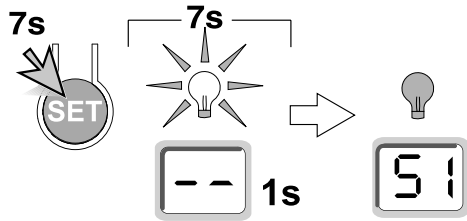

38

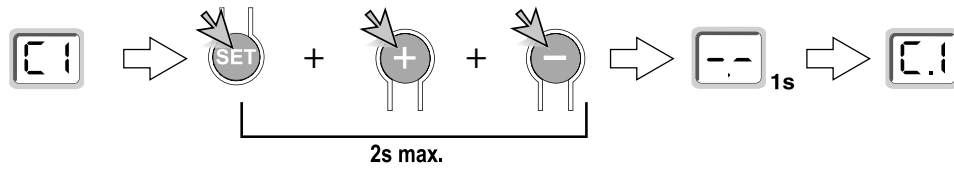

39

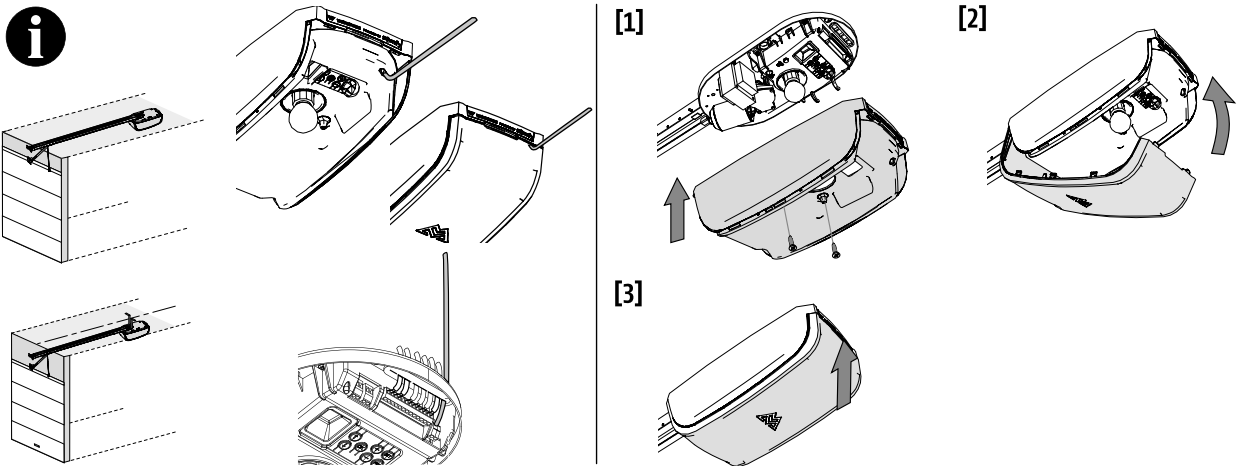

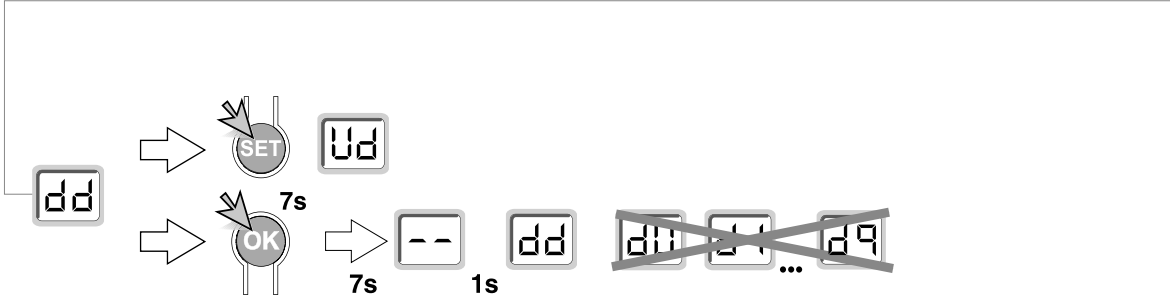
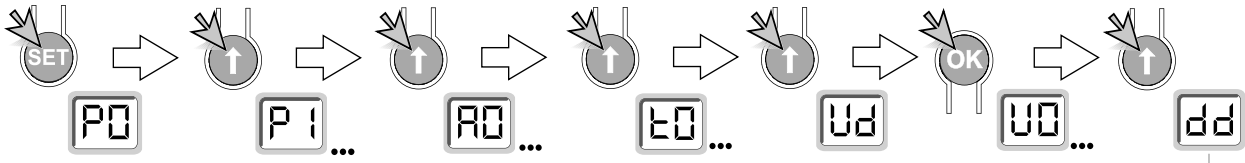

somfy®

WIŚNIEWSKI

Producent:

Somfy SAS
50 avenue du Nouveau Monde
F - 74300 CLUSES
FRANACJA

www.somfy.com

Partner biznesowy:

WIŚNIEWSKI Sp. z o.o. S.K.A.
33-311 Wielogłowy 153
POLSKA
SIRET: PL734-35-13-091

Tel : +48 18 44 77 111
Fax : +48 18 44 77 110

<http://www.wisniowski.pl/METRO>

